

# KC130GH-2P

High efficiency multicrystal photovoltaic module



## CUTTING-EDGE TECHNOLOGY

Exhaustive research work, continuous further development of production processes and highly automated production enable polycrystalline Kyocera solar modules to attain an exceptional standard of quality and markedly high levels of efficiency.

The integrated Kyocera high-performance solar cells with a standard size of 15 cm x 15.5 cm achieve over 16 % efficiency, guaranteeing an extremely high annual yield of energy from the photovoltaic system.

To protect against the harshest weather conditions, the cells are embedded between a reinforced glass covering (hailstorm resistance complying with IEC 61215 ed. 2, tested by TÜV) and EVA foil, and are sealed with a PET foil backing. The laminate is set in a sturdy aluminum frame which is easy to assemble.

The junction box on the module backside is equipped with bypass diodes that eliminate the risk of the individual solar cells overheating (hot spot effect). Many series-connected photovoltaic modules can be easily wired using pre-assembled solar cables and multi-contact plugs.

Kyocera manufactures all the components at its own production sites – without buying in semi-finished products – to ensure consistently high product quality.

## EXAMPLES OF APPLICATION

- Grid-connected systems, for e.g.
  - Residential solar power systems
  - Public and industrial solar power systems
- Solar power stations

*Apartment house*



TUVdotCOM Service: Internet platform  
for tested quality and service  
TUVdotCom-ID: 0000022553  
IEC 61215 ed. 2, IEC 61730 and  
Safety Class II  
Kyocera is ISO 9001 and ISO 14001  
certified and registered.



**KYOCERA  
SOLAR**

**We care!**

## SPECIFICATIONS

in mm

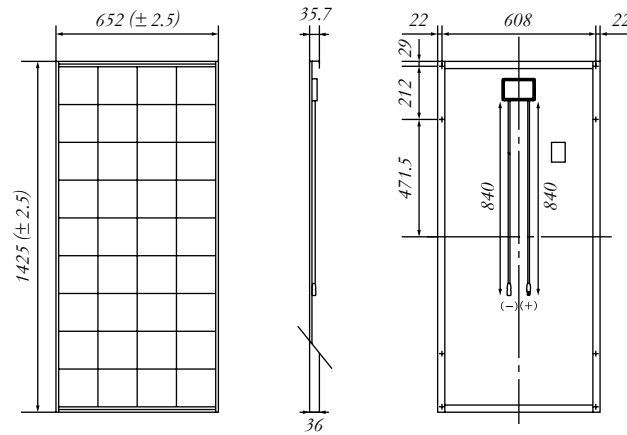

## ELECTRICAL CHARACTERISTICS

Current-Voltage characteristics at various cell temperatures

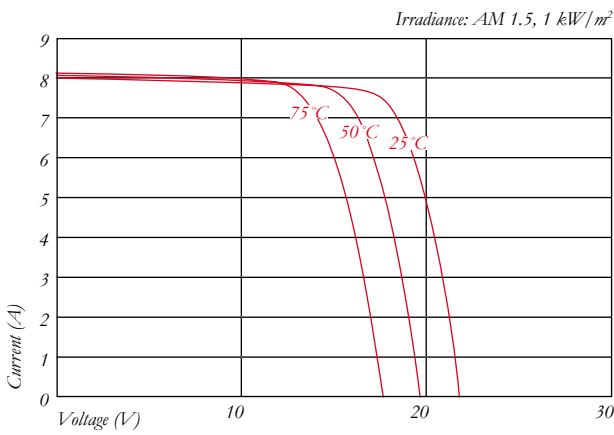

Current-Voltage characteristics at various irradiance levels

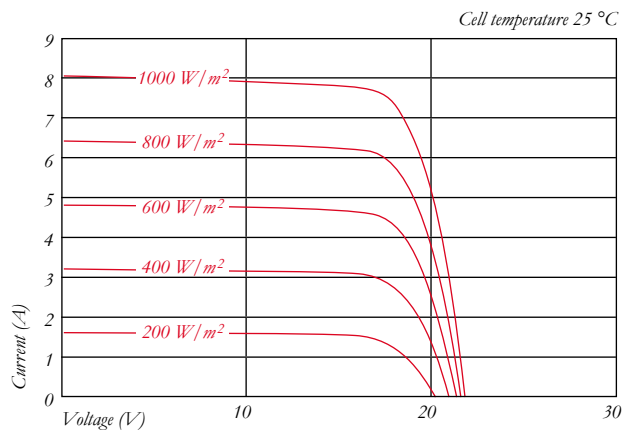

## ELECTRICAL PERFORMANCE

PV Module Type	KC130GH-2P	
<b>At 1000 W/m<sup>2</sup> (STC)*</b>		
Maximum Power	[W]	130
Maximum System Voltage	[V]	1000
Maximum Power Voltage	[V]	17.6
Maximum Power Current	[A]	7.39
Open Circuit Voltage (V <sub>OC</sub> )	[V]	21.9
Short Circuit Current (I <sub>SC</sub> )	[A]	8.02
<b>At 800 W/m<sup>2</sup> (NOCT)**</b>		
Maximum Power	[W]	92
Maximum Power Voltage	[V]	15.5
Maximum Power Current	[A]	5.94
Open Circuit Voltage (V <sub>OC</sub> )	[V]	19.9
Short Circuit Current (I <sub>SC</sub> )	[A]	6.47
NOCT	[°C]	47
Power Tolerance	[%]	+10 / -5
Maximum Reverse Current I <sub>R</sub>	[A]	15
Series Fuse Rating	[A]	15
Temperature Coefficient of V <sub>OC</sub>	[V/°C]	-8.21x10 <sup>-2</sup>
Temperature Coefficient of I <sub>SC</sub>	[A/°C]	3.18x10 <sup>-3</sup>
Temperature Coefficient of Max. Power	[W/°C]	-6.36x10 <sup>-1</sup>
Reduction of Efficiency (from 1000 W/m <sup>2</sup> to 200 W/m <sup>2</sup> )	[%]	4.3

## DIMENSIONS

Length	[mm]	1425 (±2.5)
Width	[mm]	652 (±2.5)
Depth / incl. Junction Box	[mm]	36 / 36
Weight	[kg]	12.2
Cable	[mm]	(+)840 / (-)840
Connection Type	MC PV-KBT3 / MC PV-KST3	
Junction Box	[mm]	100x108x15
IP Code	IP65	

## GENERAL INFORMATION

Performance Guarantee	10*** / 20 years****
Warranty	2 years

## CELLS

Number per Module	36
Cell Technology	multicrystal
Cell Shape (rectangular)	[mm] 150x155
Cell Bonding	3 busbar

\* Electrical values under standard test conditions (STC): irradiation of 1000 W/m<sup>2</sup>, airmass AM 1.5 and cell temperature of 25 °C

\*\* Electrical values under normal operating cell temperature (NOCT): irradiation of 800 W/m<sup>2</sup>, airmass AM 1.5, wind speed of 1 m/s and ambient temperature of 20 °C

\*\*\* 10 years on 90% of the minimally specified power P under standard test conditions (STC)

\*\*\*\* 20 years on 80% of the minimally specified power P under standard test conditions (STC)

Your local Kyocera dealer:

**KYOCERA  
SOLAR**

**We care!**

**KYOCERA Fin ceramics GmbH  
Solar Division**  
Fritz-Mueller-Str. 107  
73730 Esslingen/Germany  
Tel: +49 (0)711-93 93 49 99  
Fax: +49 (0)711-93 93 49 50  
Email: solar@kyocera.de  
www.kyocerasolar.de